

TOTAL

One-Stop Tools Station

**SUPER
SELECT**

TOTAL



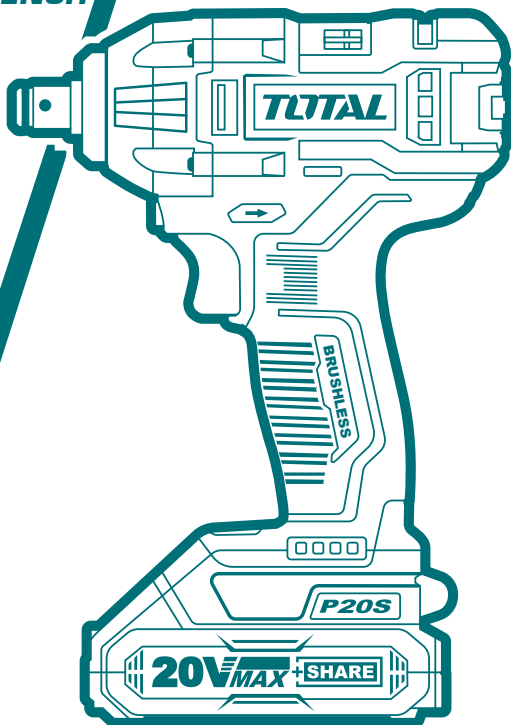







**LITHIUM-ION
IMPACT WRENCH
20V**



TIWLI2038, TIWLI2038X, TIWLI2038E, TIWLI2038XE,
TIWLI2038-X, TIWLI2038M, TIWLI2038XM, TIWLI2038XA,
UTIWLI2038, UTIWLI2038X (X stands for 1 to 9)

Original instructions

THE SYMBOLS IN INSTRUCTION MANUAL AND THE LABEL ON THE TOOL

	Double insulated for additional protection.
	Read the instruction manual before using.
	CE conformity.
	Wear safety glasses, hearing protection and dust mask.
	Waste electrical products should not be disposed of with household waste. Please recycle where facilities exist. Check with your Local Authority or retailer for recycling advice.
	Safety alert. Please only use the accessories supported by the manufacturer.
	Charging the battery only below 40°C
	Always recycle batteries
	Do not destroy battery by fire
	Do not expose battery to water

GENERAL POWER TOOL SAFETY WARNINGS

⚠ WARNING

Read all safety warnings and all instructions. *Failure to follow the warnings and instructions may result in electric shock, fire and/or serious injury.*

Save all warnings and instructions for future reference.

The term "power tool" in the warnings refers to your mains-operated (corded) power tool or battery-operated (cordless) power tool.

1) Work area safety

- a) Keep work area clean and well lit.** *Cluttered and dark areas invite accidents.*
- b) Do not operate power tools in explosive atmospheres, such as in the presence of flammable liquids, gases or dust.** *Power tools create sparks which may ignite the dust or fumes.*
- c) Keep children and bystanders away while operating a power tool.** *Distractions can cause you to lose control.*

2) Electrical safety

- a) Power tool plugs must match the outlet. Never modify the plug in any way. Do not use any adapter plugs with earthed (grounded) power tools.** *Unmodified plugs and matching outlets will reduce risk of electric shock.*
- b) Avoid body contact with earthed or grounded surfaces such as pipes, radiators, ranges and refrigerators.** *There is an increased risk of electric shock if your body is earthed or grounded.*
- c) Do not expose power tools to rain or wet conditions.** *Water entering a power tool will increase the risk of electric shock.*
- d) Do not abuse the cord. Never use the cord for carrying, pulling or unplugging the power tool. Keep cord away from heat, oil, sharp edges or moving parts.** *Damaged or entangled cords increase the risk of electric shock.*
- e) When operating a power tool outdoors, use an extension cord suitable for outdoor use.** *Use of a cord suitable for outdoor use reduces the risk of electric shock.*

f) If operating a power tools in a damp location is unavoidable, use a residual current device (RCD) protected supply. *Use of an RCD reduces the risk of electric shock.*

3) Personal safety

a) **Stay alert, watch what you are doing and use common sense when operating a power tool. Do not use a power tool while you are tired or under the influence of drugs, alcohol or medication.** *A moment of inattention while operating power tools may result in serious personal injury.*

b) **Use personal protective equipment. Always wear eye protection.** *Protective equipment such as dust mask, non-skid safety shoes, hard hat, or hearing protection used for appropriate conditions will reduce personal injuries.*

c) **Prevent unintentional starting. Ensure the switch is in the off position before connecting to power source and/or battery pack, picking up or carrying the tool.** *Carrying power tools with your finger on the switch or energizing power tools that have the switch on invites accidents.*

d) **Remove any adjusting key or wrench before turning the power tool on.** *A wrench or a key left attached to a rotating part of the power tool may result in personal injury.*

e) **Do not overreach. Keep proper footing and balance at all times.** *This enables better control of the power tool in unexpected situations.*

f) **Dress properly. Do not wear loose clothing or jewellery. Keep your hair, clothing and gloves away from moving parts.** *Loose clothes, jewellery or long hair can be caught in moving parts.*

g) **If devices are provided for the connection of dust extraction and collection facilities, ensure these are connected and properly used.** *Use of dust collection can reduce dust-related hazards.*

4) Power tool use and care

a) **Do not force the power tool. Use the correct power tool for your application.** *The correct power tool will do the job better and safer at the rate for which it was designed.*

b) Do not use the power tool if the switch does not turn it on and off.*Any power tool that cannot be controlled with the switch is dangerous and must be repaired.*

c) Disconnect the plug from the power source and/or the battery pack from the power tool before making any adjustments, changing accessories, or storing power tools.*Such preventive safety measures reduce the risk of starting the power tool accidentally.*

d) Store idle power tools out of the reach of children and do not allow persons unfamiliar with the power tool or these instructions to operate the power tool.*Power tools are dangerous in the hands of untrained users.*

e) Maintain power tools. Check for misalignment or binding of moving parts, breakage of parts and any other condition that may affect the power tools operation. If damaged, have the power tool repaired before use.*Many accidents are caused by poorly maintained power tools.*

f) Keep cutting tools sharp and clean.*Properly maintained cutting tools with sharp cutting edges are less likely to bind and are easier to control.*

g) Use the power tool, accessories and tool bits etc. in accordance with these instructions, taking into account the working conditions and the work to be performed.*Use of the power tool for operations different from those intended could result in a hazardous situation.*

5) Battery tool use and care

a) Recharge only with the charger specified by the manufacturer.*A charger that is suitable for one type of battery pack may create a risk of fire when used with another battery pack.*

b) Use power tools only with specifically designated battery packs.*Use of any other battery packs may create a risk of injury and fire.*

c) When battery pack is not in use, keep it away from other metal objects, like paper clips, coins, keys, nails, screws or other small metal objects, that can make a connection from one terminal to another.*Shorting the battery terminals together may cause burns or a fire.*

d) Under abusive conditions, liquid may be ejected from the battery; avoid contact. If contact accidentally occurs, flush with water. If liquid contacts eyes, additionally seek medical help. Liquid ejected from the battery may cause irritation or burns.

SPECIFICATIONS

Model Number		TIWLI2038, TIWLI2038X, TIWLI2038E, TIWLI2038XE, TIWLI2038-X, TIWLI2038M, TIWLI2038XM, TIWLI2038XA, (X stands for 1 to 9)	UTIWLI2038, UTIWLI2038X (X stands for 1 to 9)
Fastening capacities	Standard bolt	M10 - M20	3/8"-3/4"
	High tensile bolt	M10 - M16	3/8"-5/8"
	High tensile bolt	5 mm- 14 mm	3/16"-9/16"
No load speed (RPM)	Hard impact mode	0- 2300 /min	0- 2300 /min
	Soft impact mode	0- 1300 /min	0- 1300 /min
Impacts per minute	Hard impact mode	0- 3300 /min	0- 3300 /min
	Soft impact mode	0- 2000 /min	0- 2000 /min
Rated voltage		Max.20V	Max.20V
Charging time		1Hr approx	1Hr approx

- Due to our continuing program of research and development, the specifications herein are subject to change without notice.
- Specifications and battery cartridge may differ from country to country.

CORDLESS IMPACT WRENCH SAFETY WARNINGS

1. Hold power tool by insulated gripping surfaces, when performing an operation where the fastener may contact hidden wiring. Fasteners contacting a "live" wire may make exposed metal parts of the power tool "live" and could give the operator an electric shock.
2. Always be sure you have a firm footing. Be sure no one is below when using the tool in high locations.
3. Hold the tool firmly.
4. Wear ear protectors.
5. Do not touch the bit or the workpiece immediately after operation. They may be extremely hot and could burn your skin.
6. Keep hands away from rotating parts.

SAVE THESE INSTRUCTIONS.

⚠ WARNING: DO NOT let comfort or familiarity with product (gained from repeated use) replace strict adherence to safety rules for the subject product. MISUSE or failure to follow the safety rules stated in this instruction manual may cause serious personal injury.

SYMBOLS

The followings show the symbols used for tool.

v	volts
—	direct current
n.	no load speed
.../min r/min	revolutions or reciprocation per minute
	number of blow

IMPORTANT SAFETY INSTRUCTIONS FOR BATTERY CARTRIDGE

1. Before using battery cartridge, read all instructions and cautionary markings on (1) battery charger, (2) battery, and (3) product using battery.
2. Do not disassemble battery cartridge.
3. If operating time has become excessively shorter, stop operating immediately. It may result in a risk of overheating, possible burns and even an explosion.
4. If electrolyte gets into your eyes, rinse them out with clear water and seek medical attention right away. It may result in loss of your eyesight.
5. Do not short the battery cartridge:
 - (1) Do not touch the terminals with any conductive material.
 - (2) Avoid storing battery cartridge in a container with other metal objects such as nails, coins, etc.
 - (3) Do not expose battery cartridge to water or rain. A battery short can cause a large current flow, overheating, possible burns and even a breakdown.

6. Do not store the tool and battery cartridge in locations where the temperature may reach or exceed 50 °C (122 °F).

7. Do not incinerate the battery cartridge even if it is severely damaged or is completely worn out. The battery cartridge can explode in a fire.

8. Be careful not to drop or strike battery.

9. Do not use a damaged battery.

10. The contained lithium-ion batteries are subject to the Dangerous Goods Legislation requirements.

For commercial transports e.g. by third parties, forwarding agents, special requirement on packaging and labeling must be observed. For preparation of the item being shipped, consulting an expert for hazardous material is required. Please also observe possibly more detailed national regulations. Tape or mask off open contacts and pack up the battery in such a manner that it cannot move around in the packaging.

11. Follow your local regulations relating to disposal of battery.

SAVE THESE INSTRUCTIONS.

⚠ CAUTION: Only use genuine TOTAL batteries. Use of non-genuine TOTAL batteries, or batteries that have been altered, may result in the battery bursting causing fires, personal injury and damage. It will also void the TOTAL warranty for the TOTAL tool and charger.

Tips for maintaining maximum battery life

1. Charge the battery cartridge before completely discharged. Always stop tool operation and charge the battery cartridge when you notice less tool power.

2. Never recharge a fully charged battery cartridge. Overcharging shortens the battery service life.

3. Charge the battery cartridge with room temperature at 10 °C - 40 °C (50 °F - 104 °F). Let a hot battery cartridge cool down before charging it.

4. Charge the battery cartridge if you do not use it for a long period (more than six months).

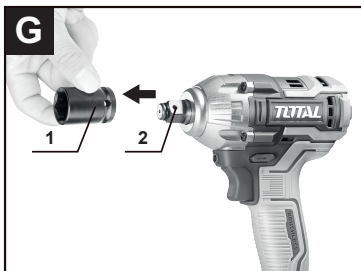
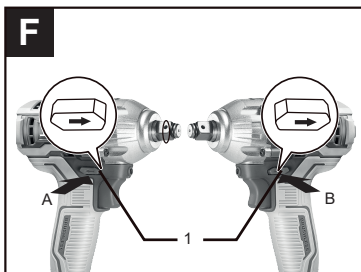
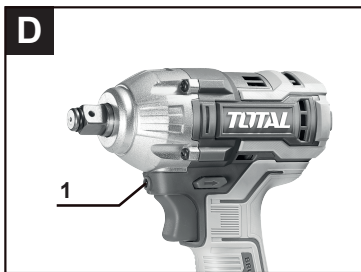
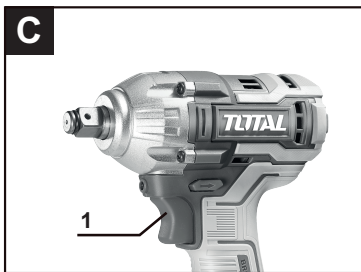
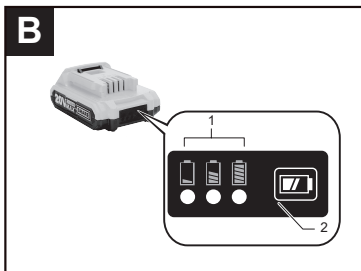

FUNCTIONAL DESCRIPTION

⚠ CAUTION: Always be sure that the tool is switched off and the battery cartridge is removed before adjusting or checking function on the tool.

INSTALLING OR REMOVING BATTERY CARTRIDGE.

⚠ CAUTION: Always switch off the tool before installing or removing of the battery cartridge.

⚠ CAUTION: Hold the tool and the battery cartridge firmly when installing or removing battery cartridge. Failure to hold the tool and the battery cartridge firmly may cause them to slip off your hands and result in damage to the tool and battery cartridge and a personal injury.

(see fig A)

1. Button 2. Battery cartridge

To remove the battery cartridge, slide it from the tool while sliding the button on the front of the cartridge.

To install the battery cartridge, align the tongue on the battery cartridge with the groove in the housing and slip it into place. Insert it all the way until it locks in place with a little click.

⚠ CAUTION: Always install the battery cartridge fully until the red indicator cannot be seen. If not, it may accidentally fall out of the tool, causing injury to you or someone around you.

⚠ CAUTION: Do not install the battery cartridge forcibly. If the cartridge does not slide in easily, it is not being inserted correctly.

INDICATING THE REMAINING BATTERY CAPACITY

(see fig B)

1. Indicator lamps 2. Check button

Press the check button on the battery cartridge to indicate the remaining battery capacity. The indicator lamps light up for few seconds.

Indicator lamps		Remaining capacity
■ Lighted	□ Off	
■ ■ ■		>80%
■ ■ □		30% to 80%
■ □ □		<30%

NOTE: Depending on the conditions of use and the ambient temperature, the indication may differ slightly from the actual capacity.

TOOL / BATTERY PROTECTION SYSTEM

The tool is equipped with a tool/battery protection system. This system automatically cuts off power to the motor to extend tool and battery life. The tool will automatically stop during operation if the tool or battery is placed under one of the following conditions:

Overload protection

When the battery is operated in a manner that causes it to draw an abnormally high current, the tool automatically stops without any indication. In this situation, turn the tool off and stop the application that caused the tool to become overloaded. Then turn the tool on to restart.

Overheat protection

When the tool/battery is overheated, the tool stops automatically. In this situation, let the tool/battery cool before turning the tool on again.

SWITCH ACTION

(see fig C)

1. Switch trigger

⚠ CAUTION: Before installing the battery cartridge into the tool, always check to see that the switch trigger actuates properly and returns to the "OFF" position when released.

To start the tool, simply pull the switch trigger. Tool speed is increased by increasing pressure on the switch trigger. Release the switch trigger to stop.

NOTE: The tool automatically stops if you keep pulling the switch trigger for about 6 minutes.

ELECTRIC BRAKE

This tool is equipped with an electric brake. If the tool consistently fails to quickly stop after the switch trigger is released, have the tool serviced at a TOTAL service center.

LIGHTING UP THE FRONT LAMP

⚠ CAUTION: Do not look in the light or see the source of light directly.

(see fig D) (see fig E)

1. Lamp 1.Button

CHANGING THE IMPACT FORCE

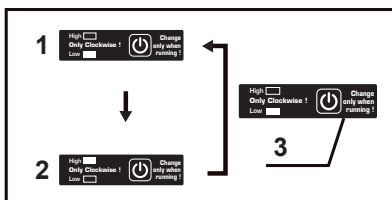

1.High 2.Low 3.Button

You can change the impact force in two steps: high,low. This allows a tightening suitable to the work.Every time the button is pressed, the number of blows changes in two steps.

REVERSING SWITCH ACTION

(see fig F)



1. Reversing switch lever

⚠ CAUTION: Always check the direction of rotation before operation.

⚠ CAUTION: Use the reversing switch only after the tool comes to a complete stop. Changing the direction of rotation before the tool stops may damage the tool.

⚠ CAUTION: When not operating the tool, always set the reversing switch lever to the neutral position.

This tool has a reversing switch to change the direction of rotation. Depress the reversing switch lever from the A side for clockwise rotation or from the B side for counterclockwise rotation.When the reversing switch lever is in the neutral position, the switch trigger cannot be pulled.



Impact force grade displayed on panel	Maximum blow	Purpose	Example of application
High 	3300min ⁻¹ /(/min)	Tightening when force and speed are desired.	Tightening wood screws, tightening bolts.
Low 	2000min ⁻¹ /(/min)	Tightening with less force to avoid screw thread breakage.	Tightening sash screws, tightening small screws such as M6.

NOTE: A mode is available only when the tool rotates clockwise. When rotating counterclockwise in A mode, the impact force and speed are the same as hard mode.

NOTE: When all lamps on the switch panel go out, the tool is turned off to save the battery power. The impact force grade can be checked by pulling the switch trigger to the extent that the tool does not operate.

NOTE: While pulling the switch trigger, the impact force grade cannot be changed.

Specifications of each impact force grade

Impact force grade displayed on panel	Maximum blows	Application	Work
High 	3300min ⁻¹ /(/min)	Tightening when force and speed are desired.	Assembling the steel frame.
Low 	2000min ⁻¹ /(/min)	Tightening when you need fine adjustment with small diameter bolt.	Assembling furnitures.

ASSEMBLY

⚠ CAUTION: Always be sure that the tool is switched off and the battery cartridge is removed before carrying out any work on the tool.

SELECTING CORRECT IMPACT SOCKET

Always use the correct size impact socket for bolts and nuts. An incorrect size impact socket will result in inaccurate and inconsistent fastening torque and/or damage to the bolt or nut.

INSTALLING OR REMOVING IMPACT SOCKET

⚠ CAUTION: Make sure that the impact socket and the mounting portion are not damaged before installing the impact socket.

⚠ CAUTION: After inserting the impact socket, make sure that it is firmly secured. If it comes out, do not use it.

(see fig G)

1. Impact socket 2. Square drive

Align the hole in the side of the impact socket with the detent pin on the square drive and push the impact socket onto the square drive until it locks into place. Tap it lightly if required. To remove the impact socket, simply pull it off.

OPERATION

⚠ CAUTION: Always insert the battery cartridge all the way until it locks in place. If you can see the red indicator on the upper side of the button, it is not locked completely. Insert it fully until the red indicator cannot be seen. If not, it may accidentally fall out of the tool, causing injury to you or someone around you.

(see fig H)

Hold the tool firmly and place the impact socket over the bolt or nut. Turn the tool on and fasten for the proper fastening time.

The proper fastening torque may differ depending upon the kind or size of the bolt, the material of the workpiece to be fastened, etc. The relation between fastening torque and fastening time is shown in the figures.

Proper fastening torque for standard bolt

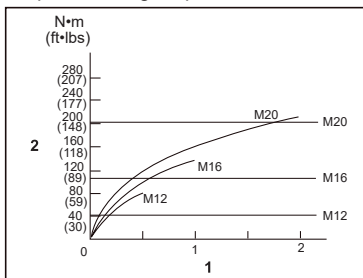

Proper fastening torque for high tensile bolt

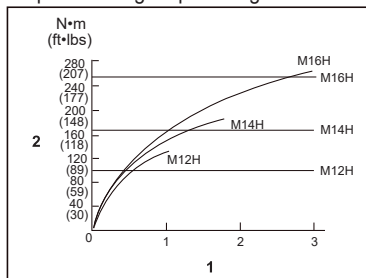

1. Fastening time (second) 2. Fastening torque

NOTE: Hold the tool pointed straight at the bolt or nut.

NOTE: Excessive fastening torque may damage the bolt/nut or impact socket. Before starting your job, always perform a test operation to determine the proper fastening time for your bolt or nut.

NOTE: If the tool is operated continuously until the battery cartridge has discharged, allow the tool to rest for 15 minutes before proceeding with a fresh battery cartridge.

The fastening torque is affected by a wide variety of factors including the following. After fastening, always check the torque with a torque wrench.

1. When the battery cartridge is discharged almost completely, voltage will drop and the fastening torque will be reduced.

2. Impact socket

- Failure to use the correct size impact socket will cause a reduction in the fastening torque.
- A worm impact socket (wear on the hex end or square end) will cause a reduction in the fastening torque.

3. Bolt

- Even though the torque coefficient and the class of bolt are the same, the proper fastening torque will differ according to the diameter of bolt.
- Even though the diameters of bolts are the same, the proper fastening torque will differ according to the torque coefficient, the class of bolt and the bolt length.

4. The use of the universal joint or the extension bar somewhat reduces the fastening force of the impact wrench. Compensate by fastening for a longer period of time.

5. The manner of holding the tool or the material of driving position to be fastened will affect the torque.

6. Operating the tool at low speed will cause a reduction in the fastening torque.

MAINTENANCE

⚠ CAUTION: Always be sure that the tool is switched off and the battery cartridge is removed before attempting to perform inspection or maintenance.

NOTICE: Never use gasoline, benzine, thinner, alcohol or the like. Discoloration, deformation or cracks may result.

To maintain product SAFETY and RELIABILITY, repairs, any other maintenance or adjustment should be performed by TOTAL Authorized or Factory Service Centers, always using TOTAL replacement parts.

**TIWLI2038, TIWLI2038X, TIWLI2038E, TIWLI2038XE,
TIWLI2038-X, TIWLI2038M, TIWLI2038XM, TIWLI2038XA,
UTIWLI2038, UTIWLI2038X (X stands for 1 to 9) Exploded view**

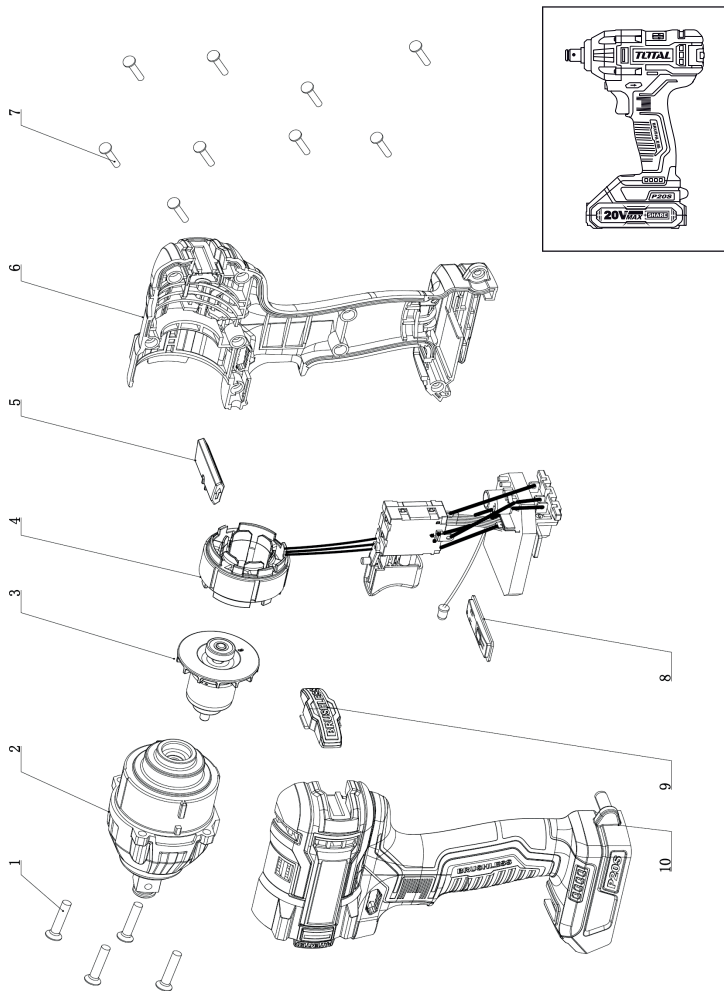

TIWLI2038, TIWLI2038X, TIWLI2038E, TIWLI2038XE,
 TIWLI2038-X, TIWLI2038M, TIWLI2038XM, TIWLI2038XA,
 UTIWLI2038, UTIWLI2038X (X stands for 1 to 9) Spare part list

No.	Part Description	Qty
1	Tapping Screw	4
2	Gear Box Assy& Hammer Assy	1
3	Rotor	1
4	Stator & Controller Assy	1
5	F/R Change Lever	1
6/10	Left&Right Shell	1
7	Tapping Screw	9
8	Function Panel	1
9	Decorative cover	1

TOTAL

One-Stop Tools Station

www.totalbusiness.com
TOTAL TOOLS CO., PTE. LTD.

   TOTAL TOOLS WORLD



MADE IN CHINA T0822.V01
No. 45 Songbei Road,
Suzhou Industrial Park, China.