

TOTAL

One-Stop Tools Station

SUPER SELECT

TOTAL

AIR TOOLS 5PCS SET
5PCS/SET

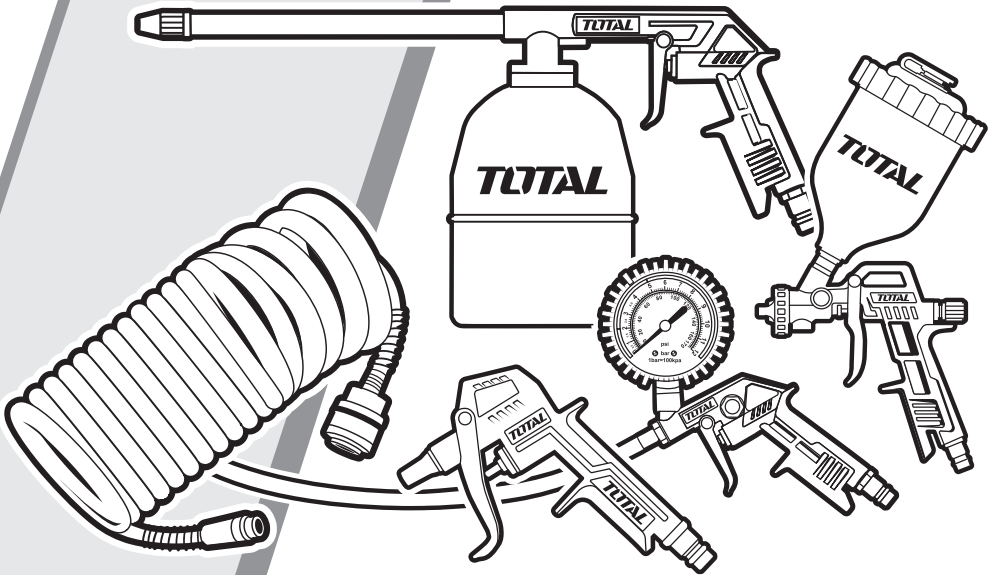

TATK053, TATK053-1, TATK053-3

Original Instructions

5 PCS AIR TOOL KIT



Warning! For your own safety, read these manual and general safety instructions carefully before using the appliance.

1. SAFETY INSTRUCTIONS

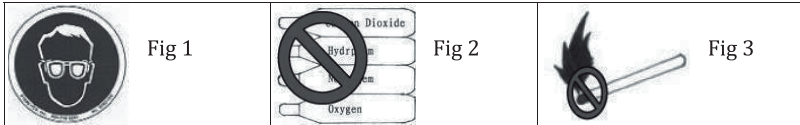

Toxic vapors produced by spraying certain materials can create intoxication and serious damage to health. Always wear protective eyewear, gloves and respirator to prevent the toxic vapor hazard, solvent and pointing paint.

Never use oxygen, combustible or any other bottle gas as a power source or would cause explosion and serious personal injury (Fig. 2).

Fluid and solvent can be highly flammable or combustible. Use in well-ventilated spray booth and avoid any ignition sources, such as smoking, open flames, etc. (Fig. 2).

Disconnect tool from air supply hose before doing tool maintenance and during non-operation, for emergency stop and prevention of unintended operation, a ball valve near the gun to air supply is recommended.

Never use homogenized hydrocarbon solvent, which can chemically react with aluminum and zinc parts.

Never point gun at you and others at any time.

Before operating the tool, make sure all the screws & caps are securely tightened to prevent leaking.





Before painting, make inspection for free movement of trigger and nozzle to insure tool can operate well.

Never modify this tool for any applications. Only use parts, nozzles and accessories recommended by manufacturers.

2. TECHNICAL DATA

	Air Spray gun	Washing gun	Air tire inflating gun	Air blow gun	Air hose
Air pressure	3-4bar	3-4bar	0-12bar	2-6.3bar	0-8bar

3. TROUBLE SHOOTING SPRAY GUN

Symptom	Problem	Solution
Fluttering or spitting 	<ol style="list-style-type: none"> 1. Material in container is litter 2. worn needle packing set 3. Fluid nozzle loose or worn 	<ol style="list-style-type: none"> 1. Add material into container 2. Lubricate or replace needle packing 3. Tighten or replace fluid nozzle
Pattern is arc 	<ol style="list-style-type: none"> 1. Worn or loose fluid nozzle 2. Material build up on air cap 	<ol style="list-style-type: none"> 1. Tighten or replace fluid nozzle 2. Remove obstructions from holes but don't use metal objects to clean it
Pattern is not evenly spread 	<ol style="list-style-type: none"> 1. Material build-up on air cap 2. Fluid nozzle dirty or worn 	<ol style="list-style-type: none"> 1. clean or replace air cap 2. Clean or replace fluid nozzle
The centre of pattern too narrow 	<ol style="list-style-type: none"> 1. Material too thin or not enough 2. Atomization air pressure too high 	<ol style="list-style-type: none"> 1. Regulate material viscosity 2. Reduce air pressure
Pattern width of fan is not sharp enough	<ol style="list-style-type: none"> 1. Material too thick 2. Atomization air pressure too low 	<ol style="list-style-type: none"> 1. Regulate material viscosity 2. Increase air pressure

4. ENVIRONMENT

Should your appliance need replacement after extended use, do not dispose of it with the household refuse, but in an environmentally safe way.

TATK053,TATK053-1,TATK053-3 Spare part list

NO.	Part Description	Qty
1	Gun body	1
2	Material Nozzle	1
3	Air ring	1
4	Air Nozzle	1
5	Locking knob	1
6	Pattern adjustment assembly	1
7	Air joint	1
8	Rivet	1
9	Trigger	1
10	Needle plug sleeve assembly	1
11	Needle socket spring	1
12	Connector	1
13	Needle Set	1
14	Gasket 3.7x6.2x0.5	1
15	Needle Spring	1
16	Needle adj. Spring	1
17	Gun body Sealing screw	1
18	Needle Sealing screw(A)	1
19	Sealing gasket	3
20	Sealing screw(A)	1
21	Tank assembly	1

TATK053, TATK053-1, TATK053-3 Exploded view

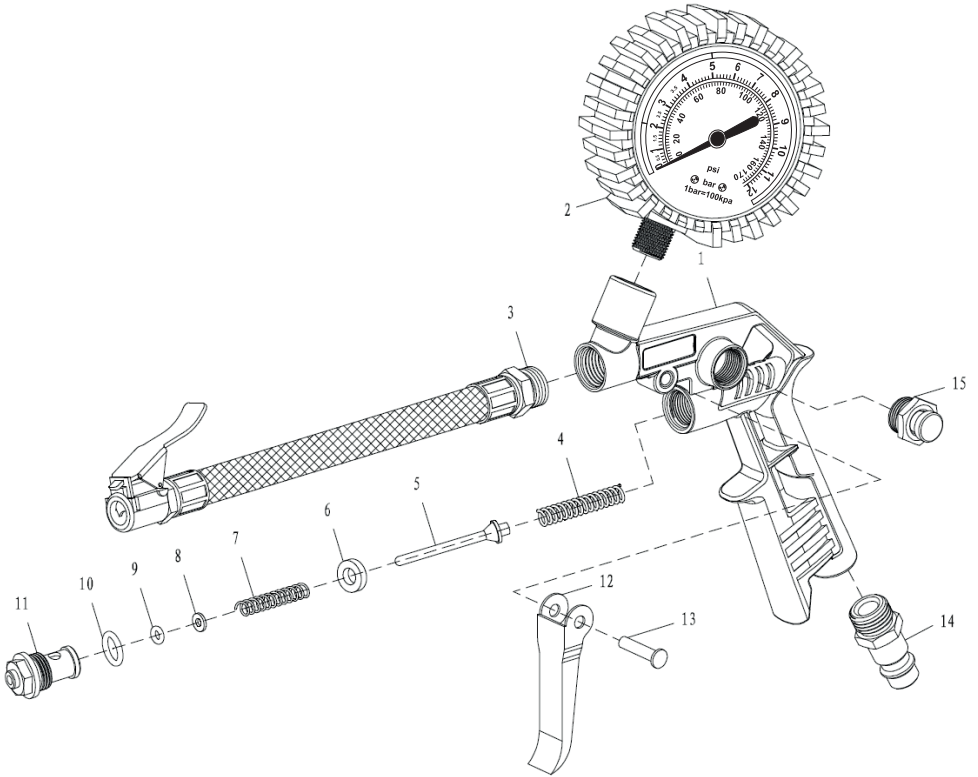
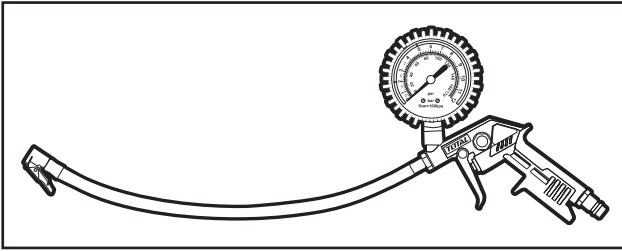

TATK053,TATK053-1,TATK053-3 Spare part list

NO.	Part Description	Qty
1	Gun body	1
2	Pressure gauge (F)	1
3	PVC tube	1
4	Air valve spring	1
5	Air valve stem	1
6	Air valve sealing gasket	1
7	Air valve spring	1
8	Gasket 3	1
9	O Ring 2*2	1
10	O Ring 8.0*1.8	1
11	Air valve body (A)	1
12	Trigger	1
13	Rivet	1
14	Air joint	1
15	Pressure relief vale assembly (C)	1

TATK053, TATK053-1, TATK053-3 Exploded view

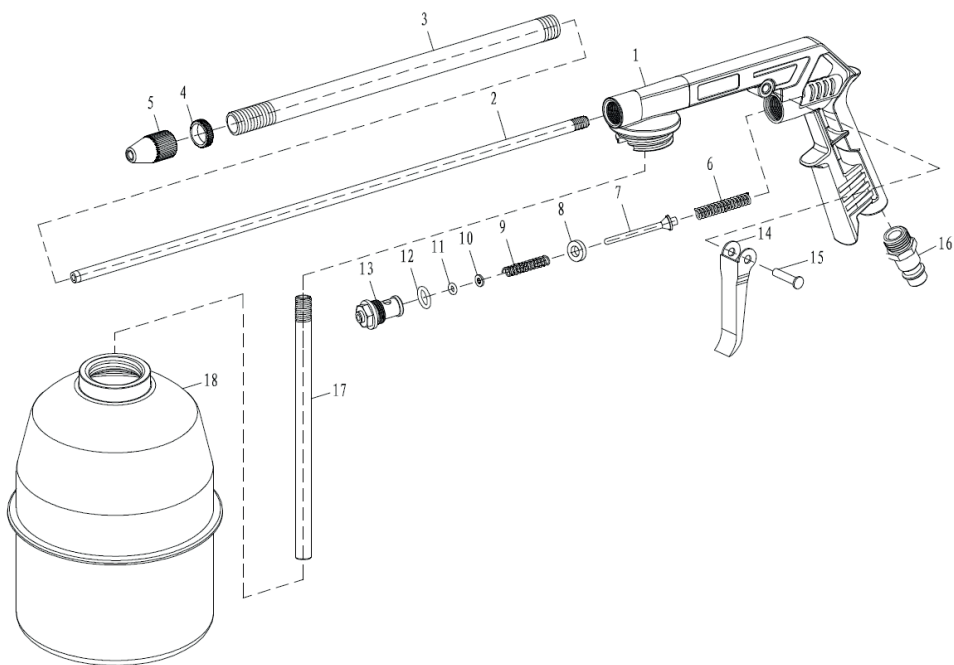
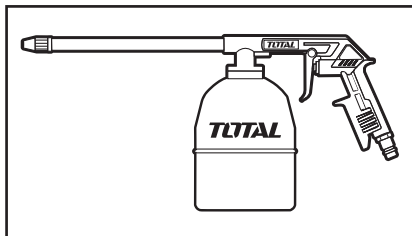

TATK053,TATK053-1,TATK053-3 Spare part list

NO.	Part Description	Qty
1	Gun body	1
2	Air tube	1
3	Material tube(A)	1
4	Locking Knob	1
5	Material nozzle	1
6	Air valve spring	1
7	Air valve stem	1
8	Air valve sealing gasket	1
9	Air valve spring	1
10	Gasket 3	1
11	O Ring 2*2	1
12	O Ring 8.0*1.8	1
13	Air valve body(A)	1
14	Trigger	1
15	Rivet	1
16	Air joint	1
17	Material tube	1
18	Cup	1

TATK053, TATK053-1, TATK053-3 Exploded view

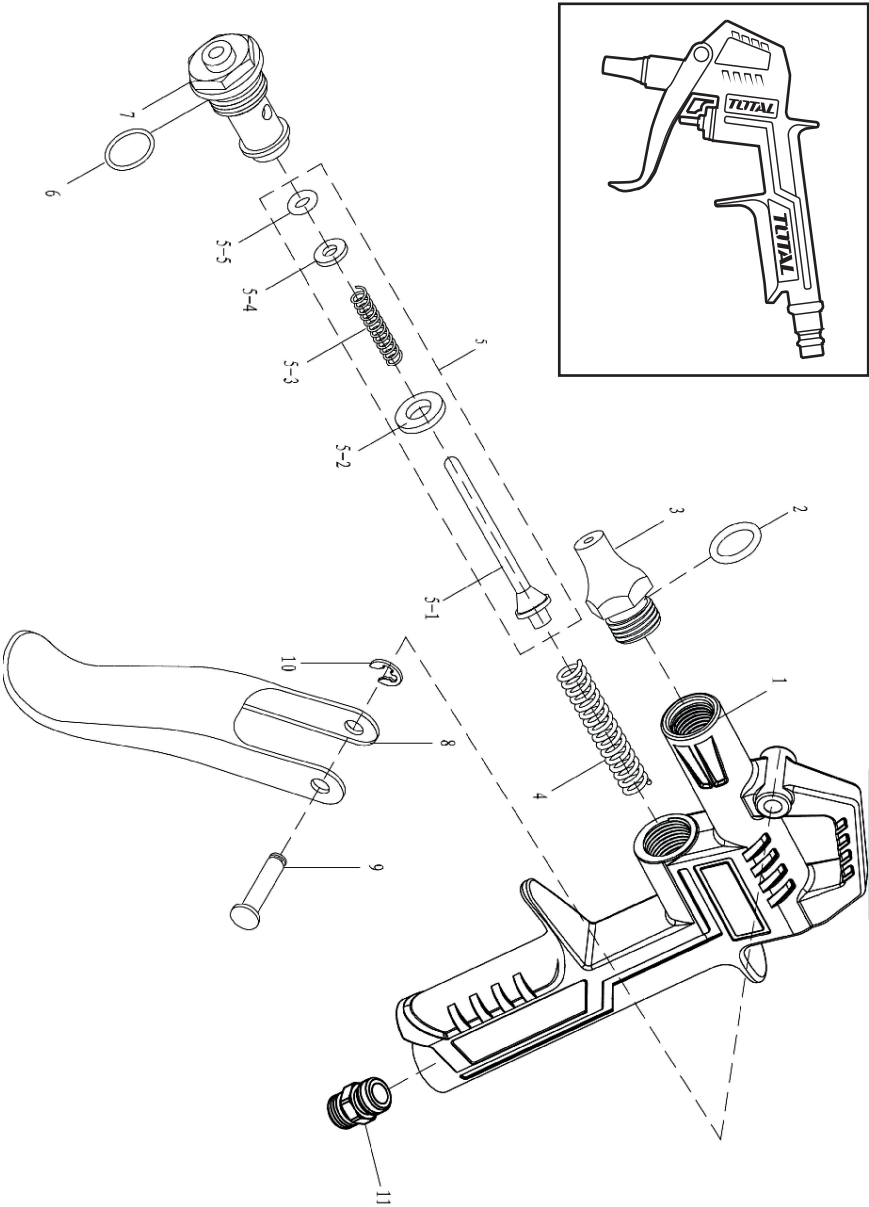

TATK053,TATK053-1,TATK053-3 Spare part list

NO.	Part Description	Qty
1	Gun body	1
2	O Ring 5.0×1.8	1
3	Nozzle C	1
4	Air valve spring	1
5	Valve stem assembly	1
5-1	Air valve stem	1
5-2	Valve seal	1
5-3	Air valve compression spring	1
5-4	Washer 3	1
5-5	O Ring 2×2	1
6	O Ring 8.0×1.8	1
7	Air valve seat	1
8	Trigger	1
9	Trigger pin	1
10	Opening stopper 3.0	1
11	Air Joint	1

TOTAL

One-Stop Tools Station

www.totalbusiness.com
TOTAL TOOLS CO., PTE. LTD.



MADE IN CHINA T0722.V06
No. 45 Songbei Road,
Suzhou Industrial Park, China.

